

PARTNER



IPL, K 950 Active, 2002-10, 106 24 93-64

K 950 Active

Reservdelar

Spare parts

Ersatzteile

Pieces de rechange

Piezas de repuesto

Ricambi

***Peças
sobresselente***

106 24 93-64

PARTNER[®]

No.	Pos.	Description	No.	Pos.	Description
501 22 03-01	M	Welch plug.	503 90 17-01	J	Ignition module
501 22 04-01	M	Ball	503 97 83-01	E	Muffler
501 22 05-01	M	Spring	503 98 82-01	M	Screen
501 22 12-01	M	Fuel pump diaphragm	505 27 75-16	J	Insulation cap
501 22 13-01	M	Gasket, pump side	505 31 65-50	M	Inlet needle
501 22 15-01	M	Screw	505 39 75-13	B	Decal
501 22 20-01	M	Lever	506 02 87-01	B	Washer
501 22 21-01	M	Shaft	506 02 88-30	B	Bushing
501 22 25-01	M	Spring	506 03 88-01	B	Decal
501 48 52-01	M	Screw	506 03 95-20	B	Bushing
501 48 54-02	J	Spark plug conn.kit	506 03 95-25	B	Bushing
501 53 16-01	J	Cable	506 07 08-01	A	Spacer
501 63 48-01	J	Spring	506 07 09-01	B	Washer
501 67 32-03	J	Pawl	506 07 18-02	A	Pulley 16"
501 69 17-02	N	Comb. tool	506 09 56-02	P	Clamp
501 76 83-05	G	Hose	506 13 35-01	L	Bracket
501 76 83-31	G	Hose	506 13 95-11	AB	Washer
501 81 99-01	J	Screw	506 13 96-01	AB	Screw
501 82 18-01	M	Retaining ring	506 14 32-01	A	Catch
501 83 98-01	J	Cable	506 15 55-06	E	Cylinder cpl
503 12 79-02	H	Starter handle	506 15 82-01	E	Gasket
503 14 29-02	J	Washer	506 16 91-01	E	Conductor
503 14 51-01	C	Clutch spring	506 21 68-11	G	Tank unit cpl
503 20 00-45	A	Screw	506 22 16-12	K	Cylinder cover
503 20 02-12	B	Screw	506 22 17-01	K	Filter cover
503 20 02-16	EGKLQ	Screw	506 22 18-11	K	Filter base
503 20 02-30	K	Screw	506 22 19-01	L	Pipe
503 20 02-55	L	Screw	506 22 22-02	H	Air conductor
503 20 19-75	E	Screw	506 22 27-01	G	Throttle trigger
503 20 25-20	J	Screw	506 22 28-01	G	Throttle lock
503 20 30-11	A	Screw	506 22 29-01	G	Spring
503 20 34-19	CH	Screw	506 22 31-01	L	Rod
503 20 34-42	K	Screw	506 22 39-01	L	Flange
503 21 05-22	G	Screw	506 22 94-01	K	Jet
503 21 05-45	G	Screw	506 23 12-01	L	Guide
503 21 06-19	P	Screw	506 23 13-01	G	Handle
503 21 07-22	H	Screw	506 23 14-01	C	Wheel 16"
503 21 28-06	J	Screw	506 23 14-02	C	Wheel 12" 14"
503 21 28-10	H	Screw	506 23 18-01	K	Air filter
503 22 10-11	J	Lock nut M8x1	506 23 19-01	K	Filter
503 22 65-04	Q	NUT	506 23 20-11	L	Choke control
503 22 66-01	A	Nut	506 23 23-01	G	Spring
503 23 00-42	J	Washer	506 23 24-01	D	Gasket
503 23 01-01	J	Washer 8.4x16	506 23 26-01	G	Plate
503 23 01-04	A	Washer 15x21	506 26 33-05	D	Crankcase cpl
503 23 04-02	E	Washer	506 23 59-03	H	Starter cpl
503 23 51-08	J	Spark plug RCJ7Y	506 23 61-01	G	Tank vent.
503 25 00-02	DF	Ball bearing 6203C3QE6	506 23 75-01	G	Spring
503 25 21-01	A	Ball bearing	506 24 39-01	K	Decal
503 25 38-01	C	Needle bearing	506 25 14-01	H	Washer
503 25 61-01	EF	Needle bearing	506 25 30-01	H	Spring
503 26 02-05	D	Sealing ring	506 25 59-32	G	Tank cap
503 26 30-21	P	O-ring	506 25 64-02	M	Insert
503 28 04-02	L	Carburettor	506 25 81-02	H	Starter pulley
503 28 90-24	E	Piston ring	506 25 84-01	M	Gasket
503 40 06-07	L	Hose	506 25 85-01	M	Diaphragm
503 45 46-01	G	Elbow	506 25 88-01	M	Gasket set
503 46 02-02	E	Piston cpl	506 25 89-01	H	Return spring
503 46 85-01	G	Anti-vib element	506 26 31-01	H	Sleeve
503 53 36-01	M	Cover	506 26 35-13	A	Housing
503 53 39-01	M	Nipple	506 26 41-01	G	Filter
503 56 00-02	L	Clamp	506 26 41-11	G	Fuel filter cpl
503 57 76-02	G	Hose	506 26 54-01	C	Clutch cover
503 57 86-01	M	Ball	506 26 63-02	BQ	Lining
503 57 87-01	M	Screw	506 26 64-01	B	Ratchet plate
503 57 89-01	G	Holder	506 26 65-01	B	Flange
503 66 56-01	E	Valve	506 26 66-01	A	Tensioner
503 67 80-01	L	Support ring	506 26 68-01	A	Spring
503 70 15-01	C	Clutch cpl	506 27 11-01	G	Fuel filter weight
503 78 26-74	F	Crankshaft			

No.	Pos.	Description	No.	Pos.	Description
506 27 14-01	M	Screw	725 53 29-55	AB	Screw mc6s 5x16
506 27 23-01	H	Decal	725 53 31-55	BQ	Screw mc6s 5x20
506 27 24-01	K	Decal	725 53 40-55	D	Screw mc6s 5x45
506 27 25-01	L	Protector	725 53 72-55	E	Screw mc6s 6x25
506 27 27-01	J	Flywheel cpl	737 44 13-00	E	Clip
506 27 31-01	D	Buffer	740 43 13-00	H	O-ring
506 27 63-01	M	Repair kit	740 48 20-03	K	O-ring
506 27 84-11	K	Label epa			
506 27 84-12	K	Label ce			
506 27 84-23	K	Label Canada			
506 27 92-01	A	Cover 16"			
506 27 93-01	A	Cover 12" 14"			
506 28 39-30	K	Sealing			
506 28 40-02	B	Label 12"			
506 28 40-04	B	Label 12"			
506 28 40-12	B	Label 14"			
506 28 40-14	B	Label 14"			
506 28 40-22	B	Label 16"			
506 28 40-24	B	Label 16"			
506 28 44-01	A	Bolt			
506 28 53-01	G	Spring			
506 28 59-01	C	Spacer			
506 28 63-01	M	Spring			
506 28 68-01	M	Cover			
506 28 73-01	A	Nut			
506 28 74-01	L	Intake			
506 28 84-01	B	Ratchet plate			
506 28 95-01	G	Nipple			
506 29 05-02	N	Gasket set			
506 29 09-01	M	Throttle shaft kit			
506 29 10-01	M	Throttle shaft sealing kit			
506 29 11-01	M	Choke shaft kit			
506 29 13-01	M	Jets and plugs kit			
506 29 21-01	G	Gasket			
506 29 45-01	G	Support 14" 16"			
506 29 50-01	G	Spark arrestor 12"			
506 29 56-01	P	Nipple			
506 29 57-01	P	Nipple			
506 29 75-01	Q	Handle			
506 29 76-01	Q	Harness			
506 29 83-63	A	Shaft			
506 29 88-01	P	Screw			
506 30 23-01	Q	Decal			
506 30 24-01	Q	Decal			
506 30 25-01	Q	Bracket			
506 30 40-11	Q	Decal			
506 30 40-12	Q	Decal			
506 30 40-13	Q	Decal			
506 31 07-01	C	Decal			
506 31 77-11	P	Valve cpl			
506 31 86-01	J	Stop switch			
506 32 20-01	Q	Decal			
506 32 21-01	K	Decal			
506 32 22-01	Q	Decal			
506 32 48-01	B	Sleeve			
506 32 87-01	P	Y-tube			
506 32 89-03	P	Wet cutting kit			
506 33 56-15	H	Starter rope			
506 33 72 01	H	Cover			
506 34 05-12	B	Guard 12"			
506 34 05-14	B	Guard 14"			
506 34 05-16	B	Guard 16"			
506 34 05-24	Q	Guard rescue 14"			
506 34 46-01	BPQ	Handle			
506 34 74-03	A	Belt 12" 14"			
506 34 74-04	A	Belt 16"			
506 34 78-01	A	Pulley 12" 14"			
506 35 27-01	P	Spring			
720 12 40-20	G	Pin			
720 13 07-10	D	Pin			

A *compl 506 27 93-01 (12", 14")
*compl 506 27 92-01 (16")

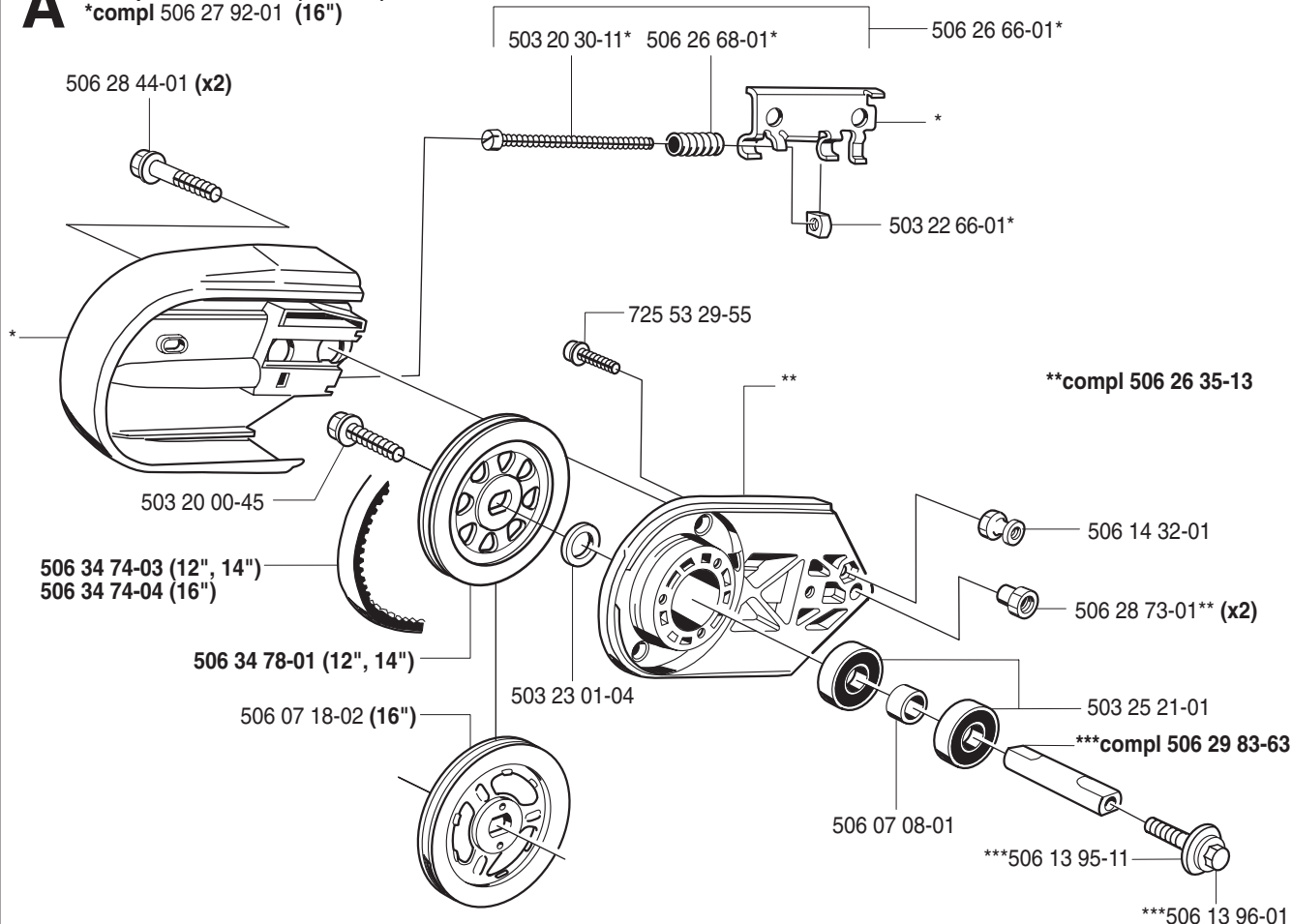

B *compl 506 34 05-12 (12")
*compl 506 34 05-14 (14")
*compl 506 34 05-16 (16")

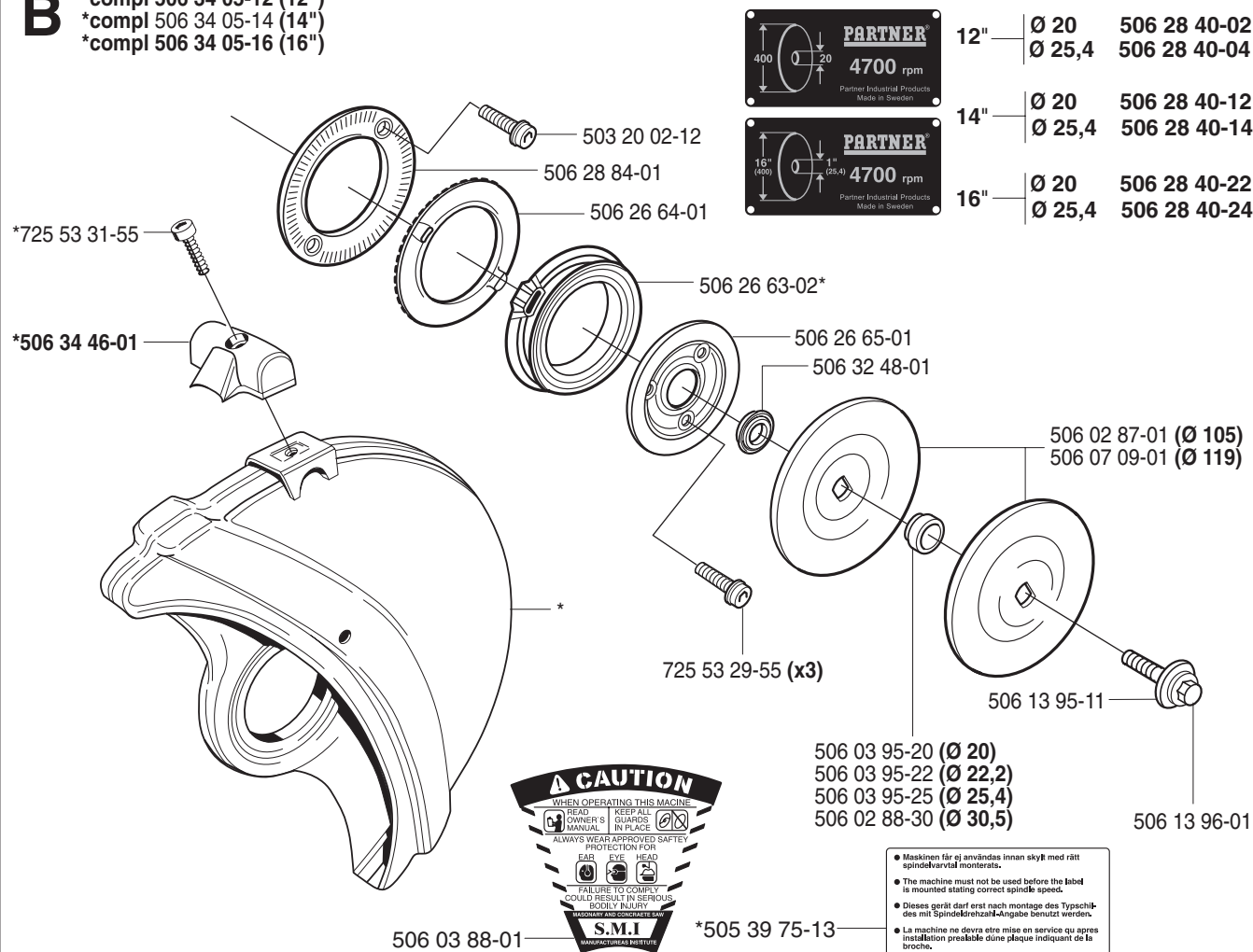

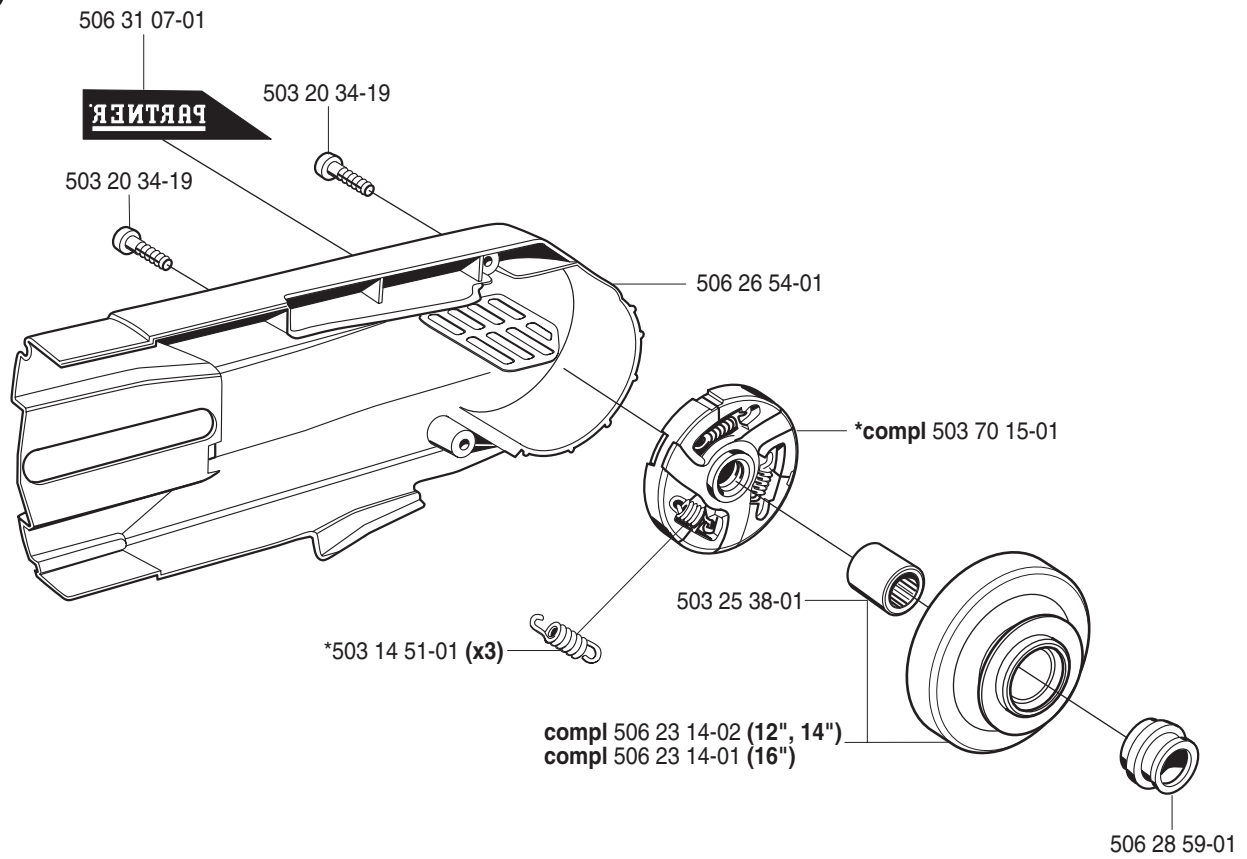
C**D**

Crankcase
*compl 506 23 33-05

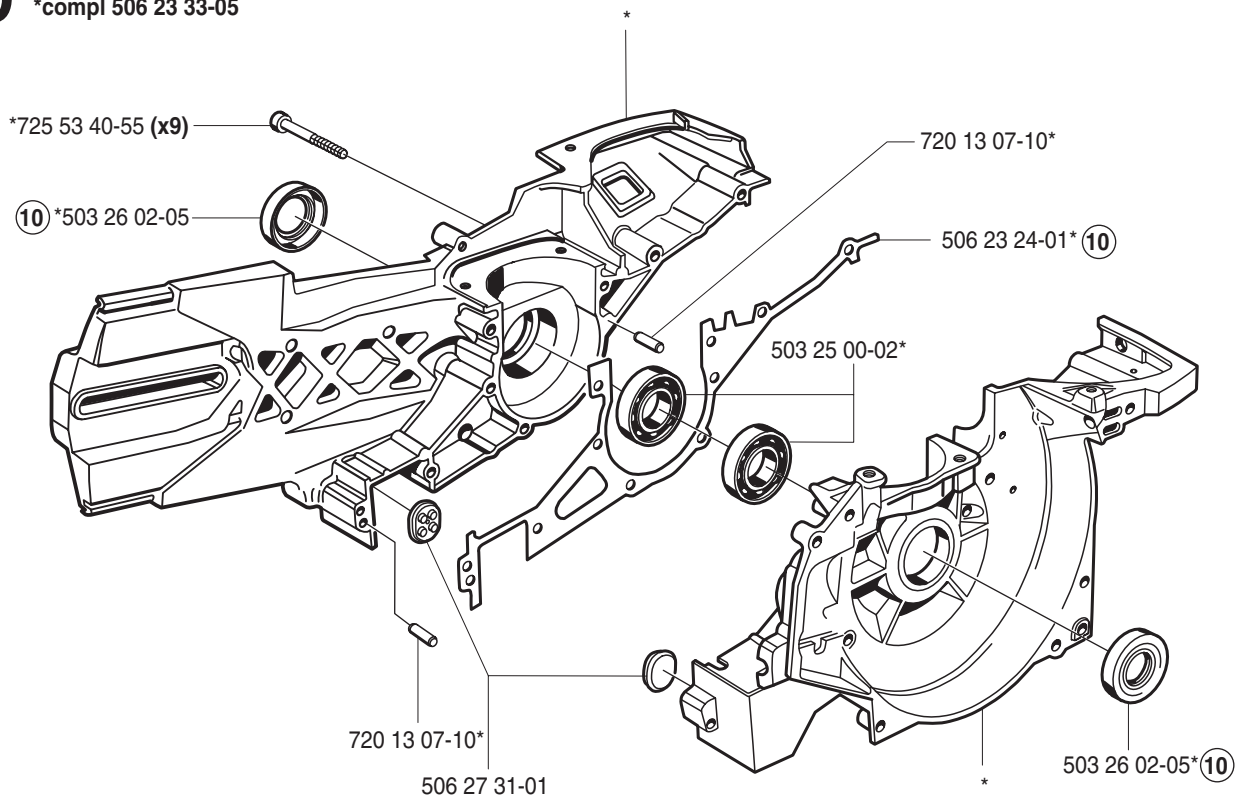

E Cylinder and piston
 *compl 506 15 55-06

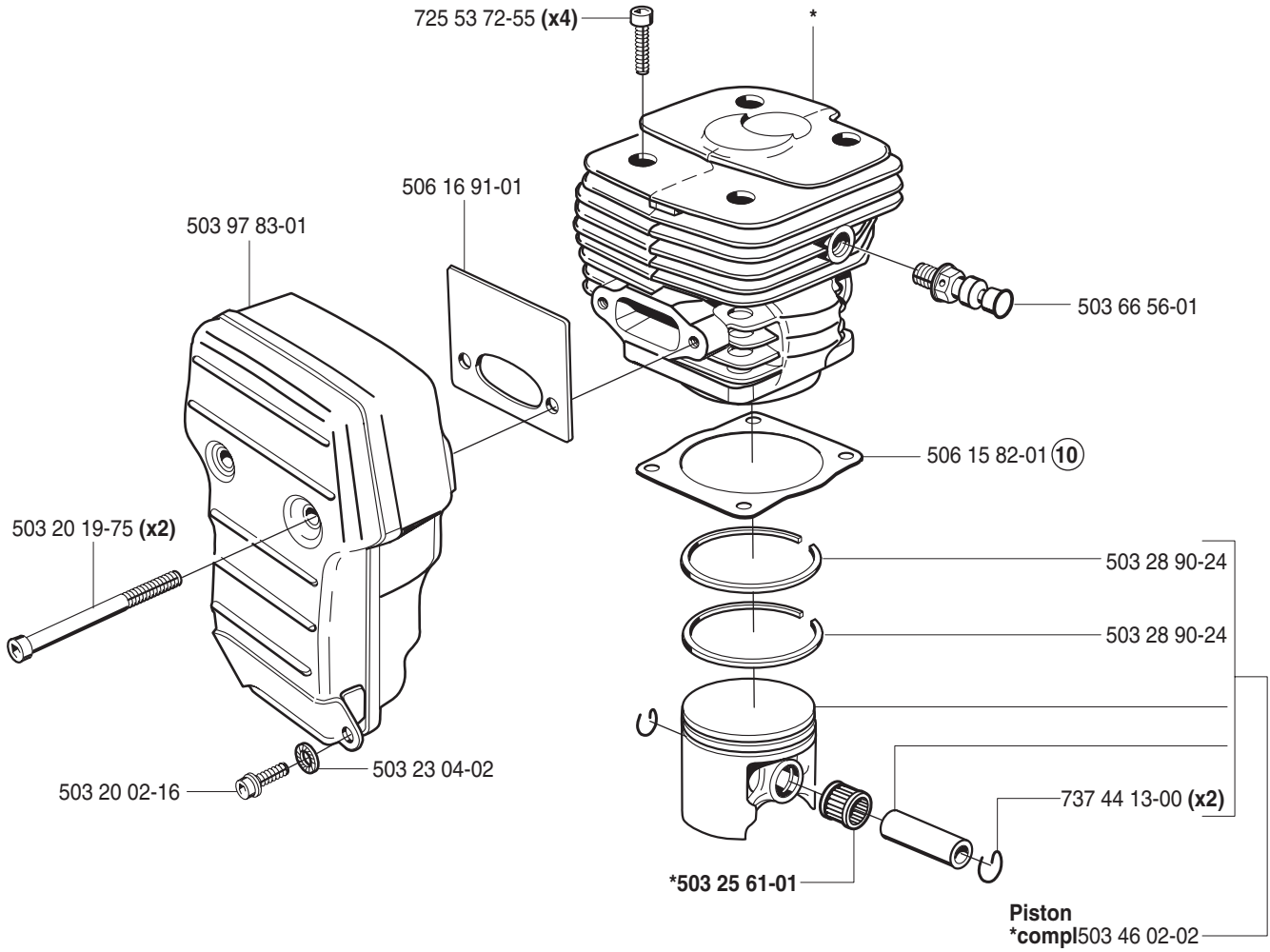

F **compl 503 78 26-74

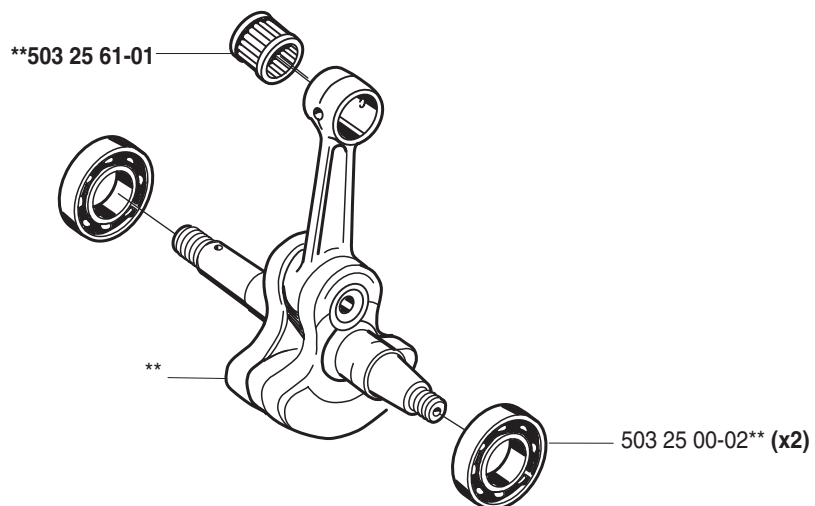

G

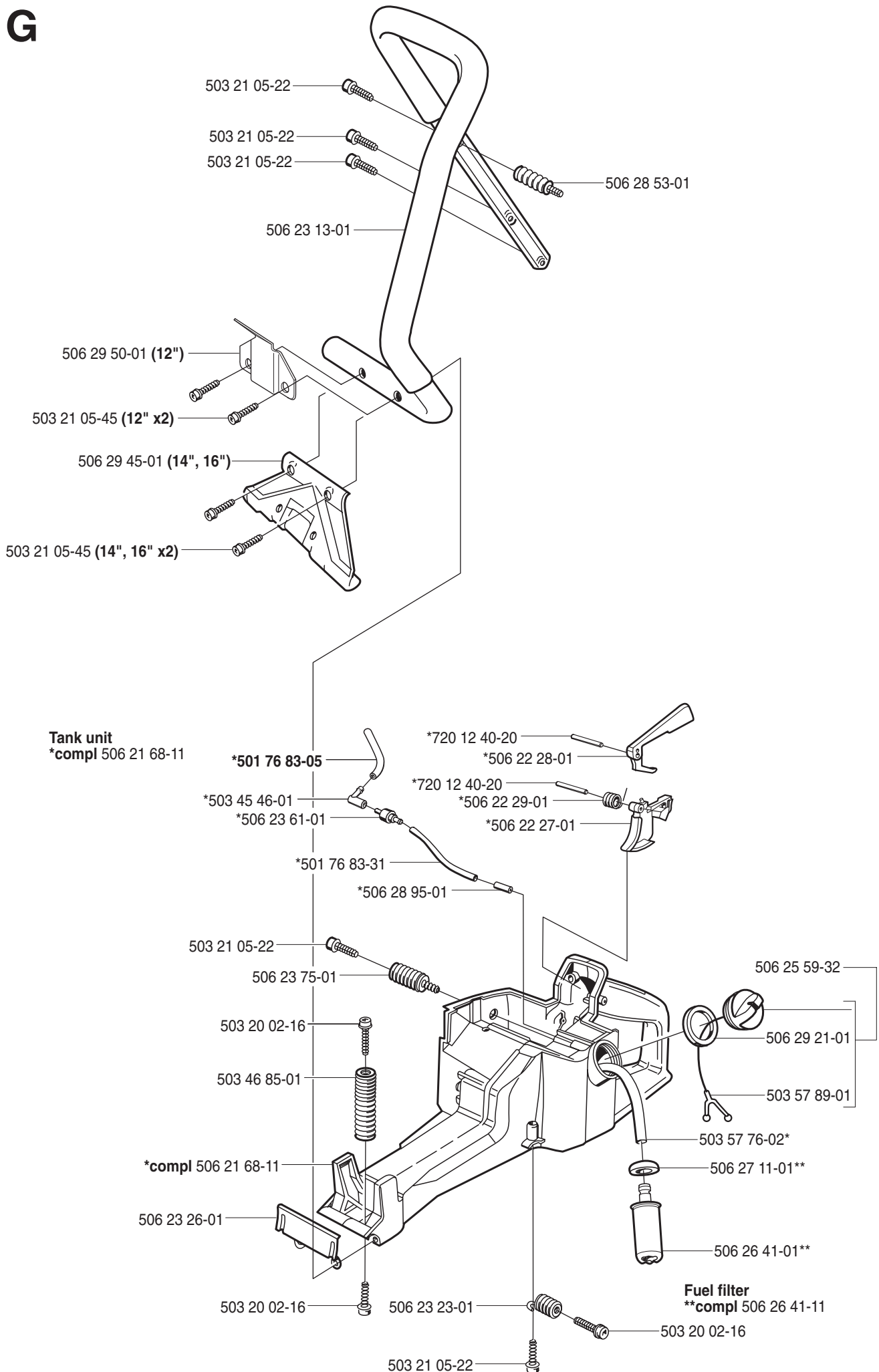

H Starter
compl 506 23 59-03

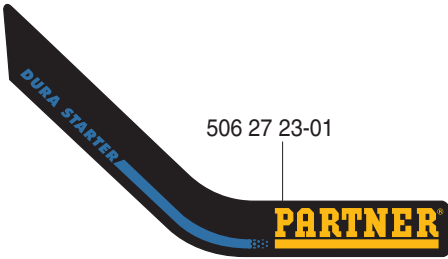
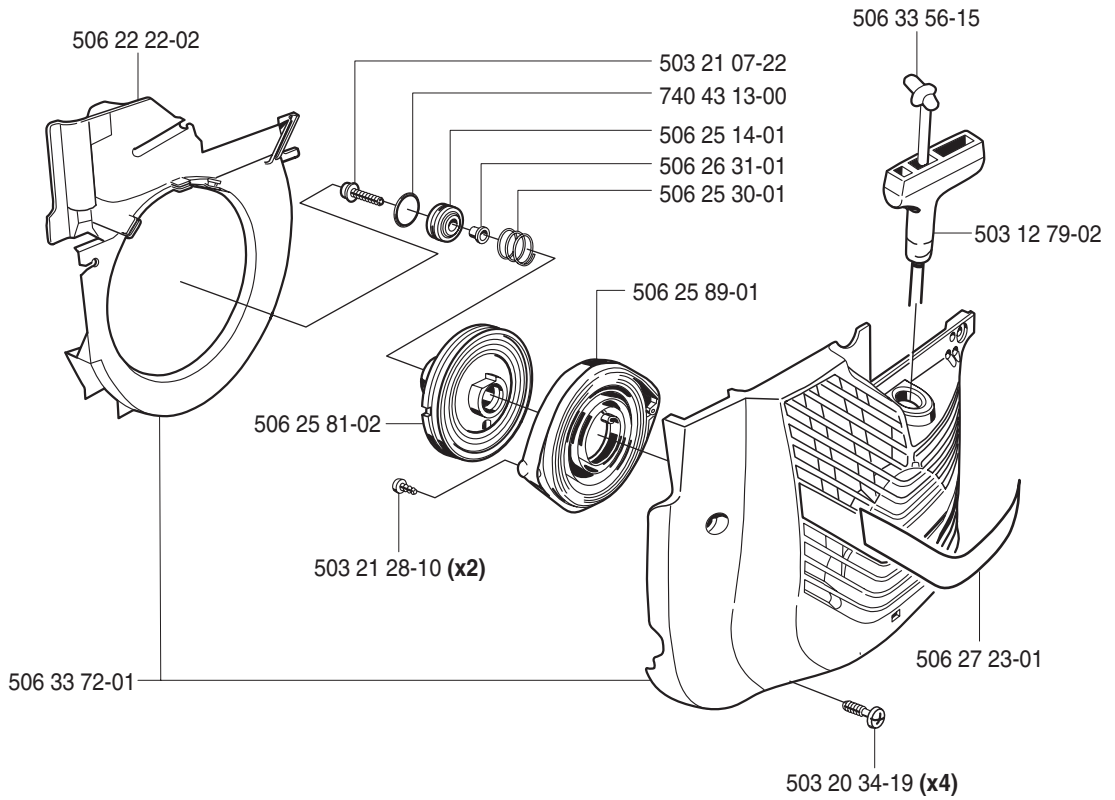

J

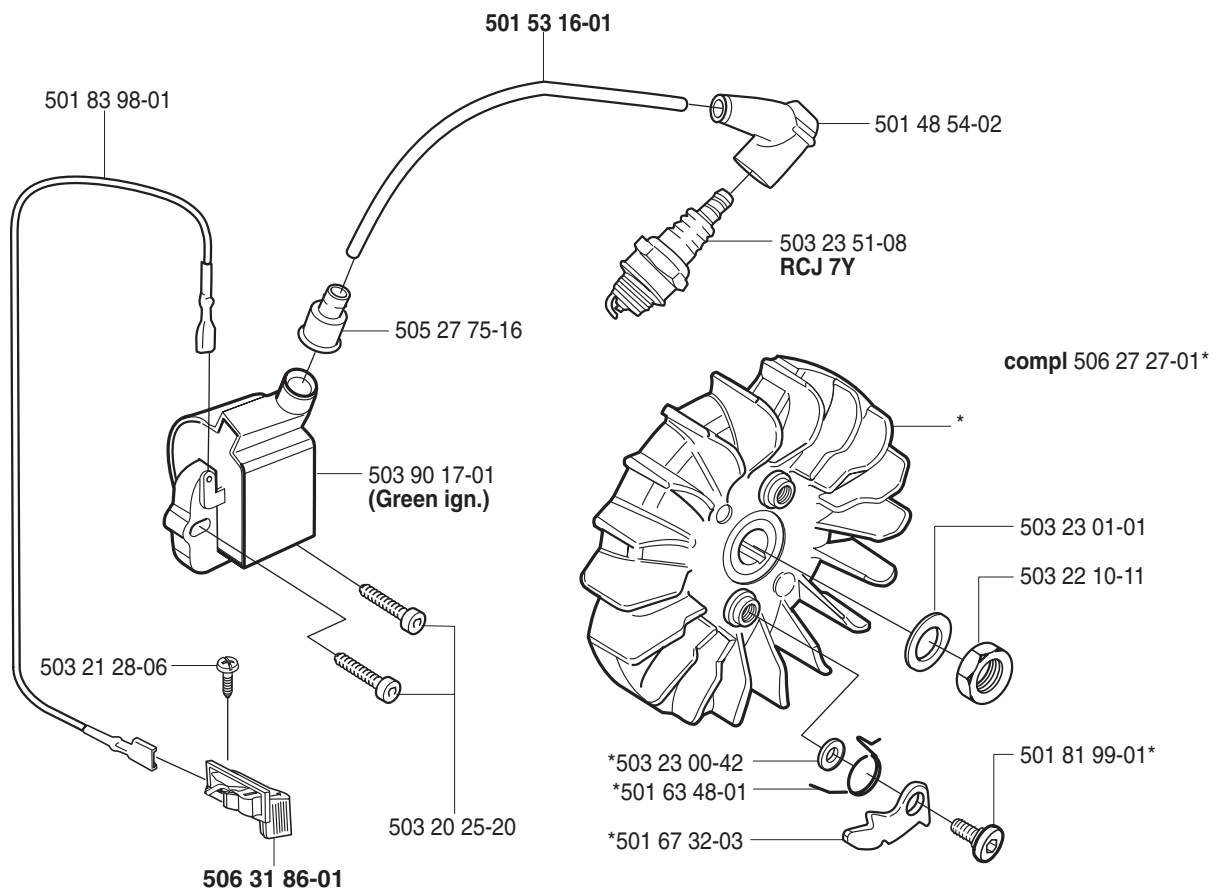

K *compl 506 22 16-12
 **compl 506 22 18-11

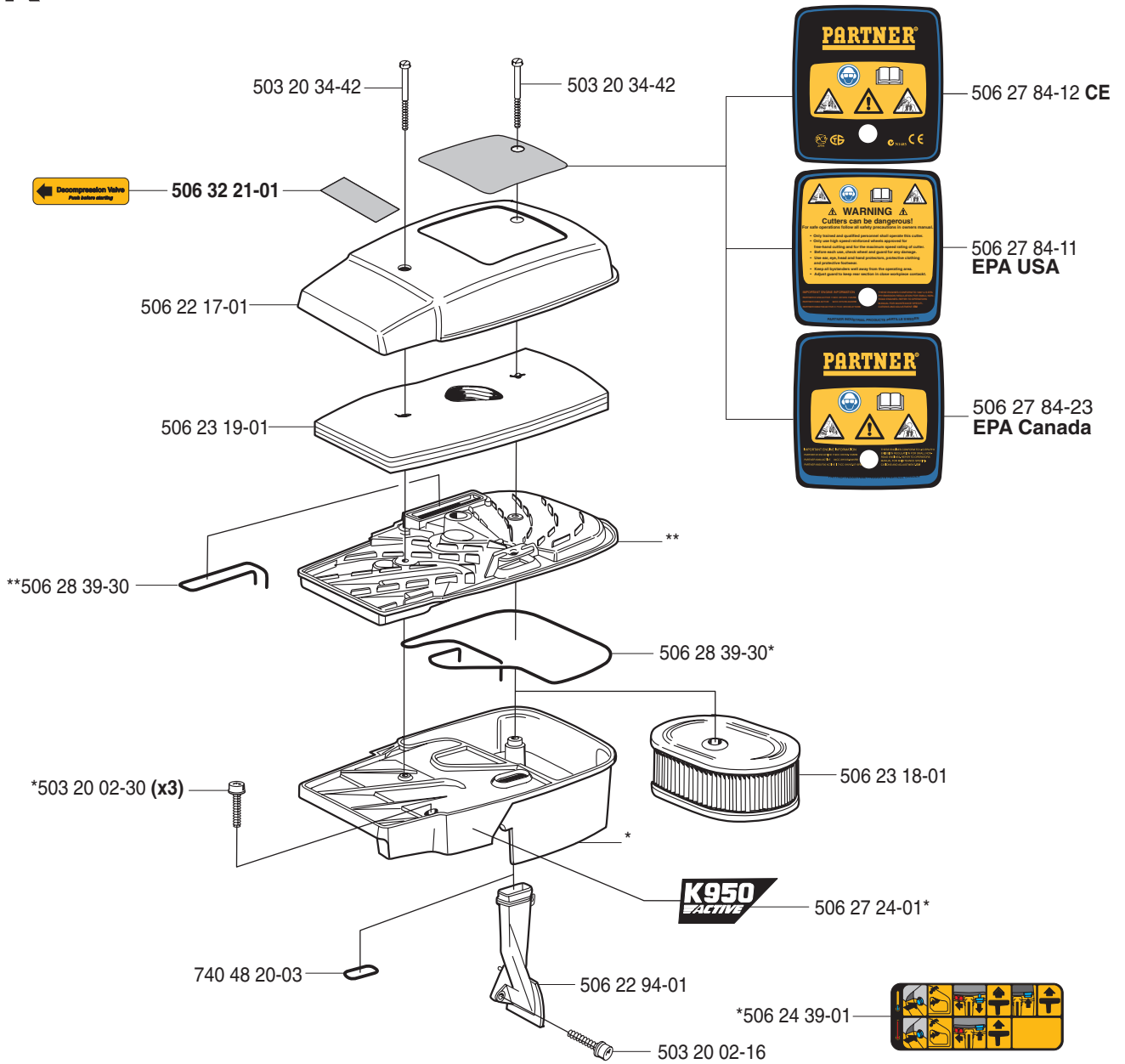

L

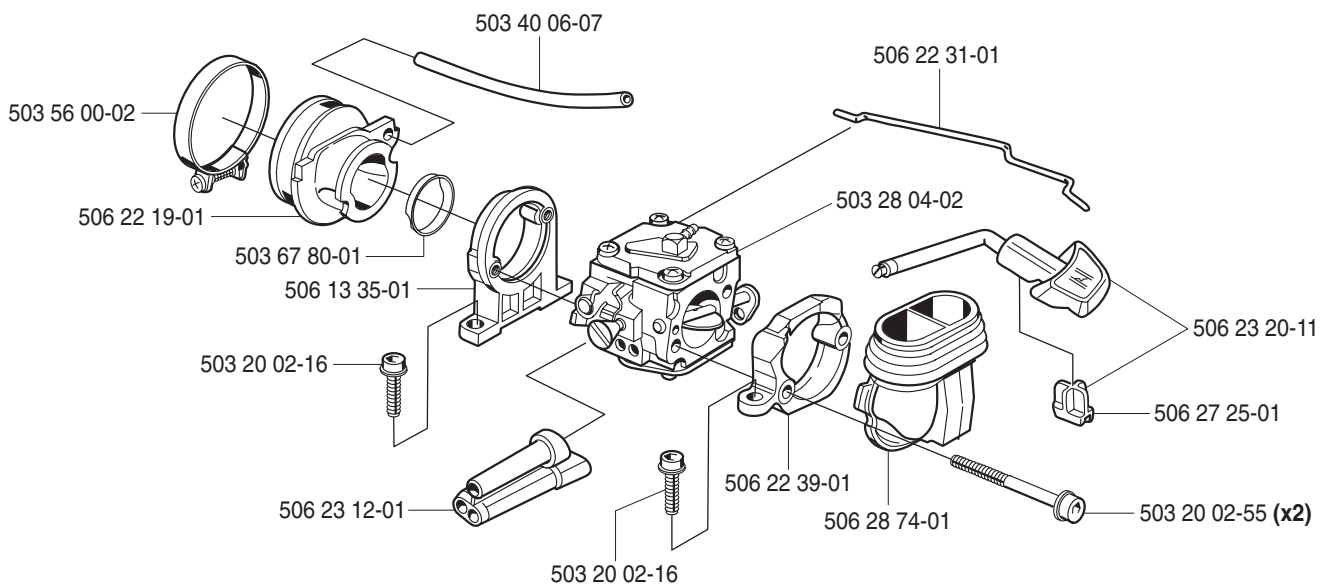

M

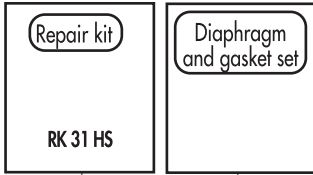

506 27 63-01 506 25 88-01

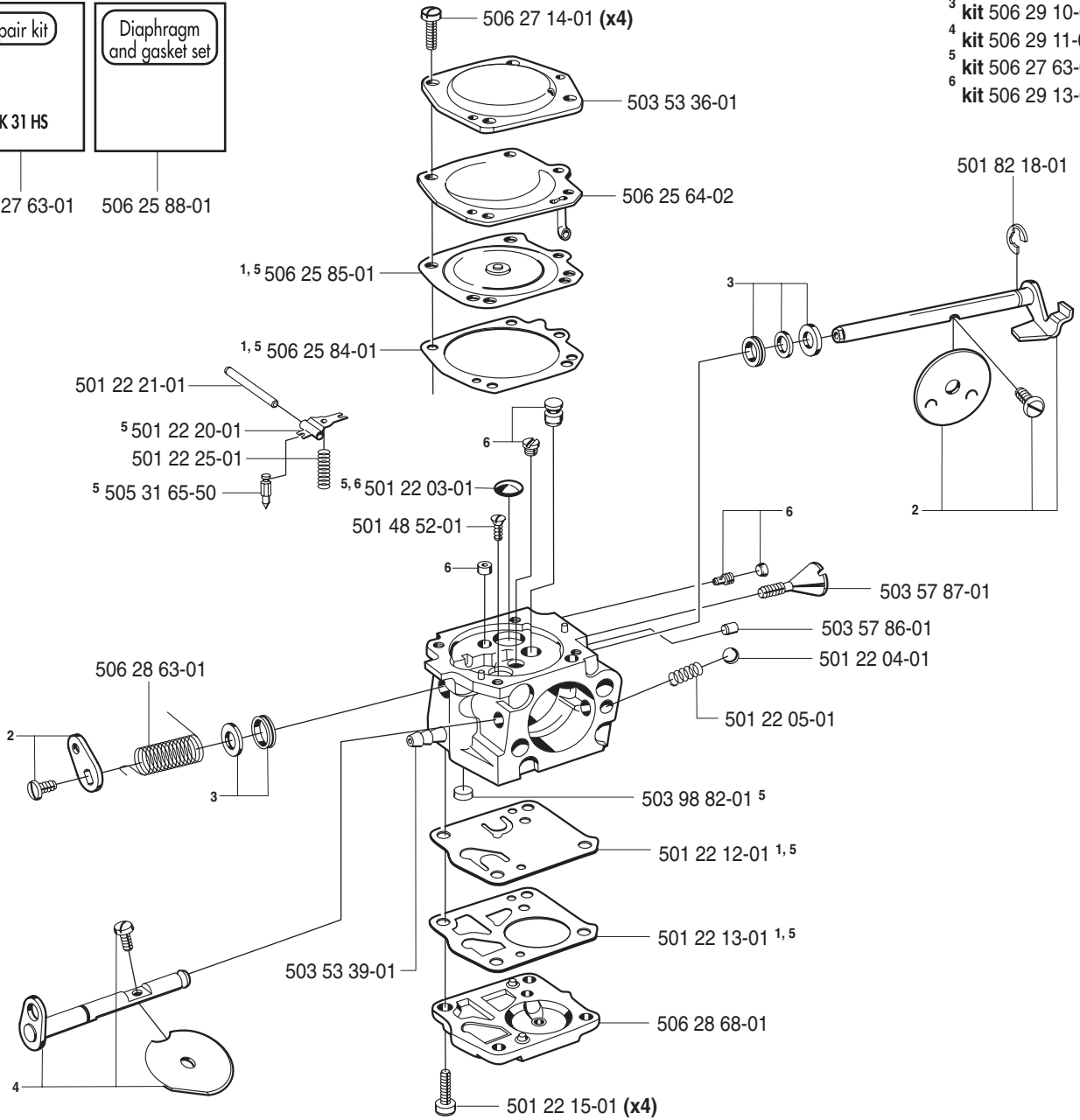

- 1 kit 506 25 88-01
- 2 kit 506 29 09-01
- 3 kit 506 29 10-01
- 4 kit 506 29 11-01
- 5 kit 506 27 63-01
- 6 kit 506 29 13-01

N



506 29 05-02 (10)

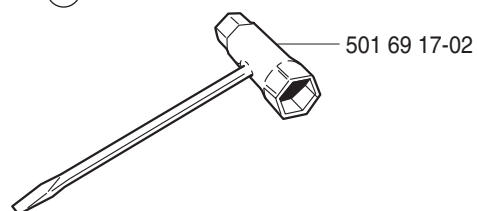

P Wet cutting kit
 *compl 506 32 89-03

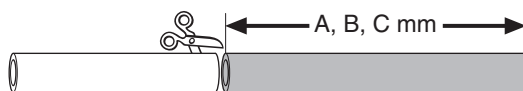
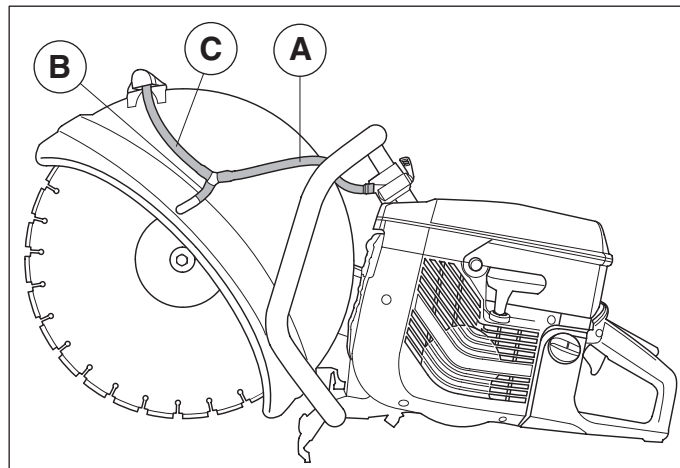
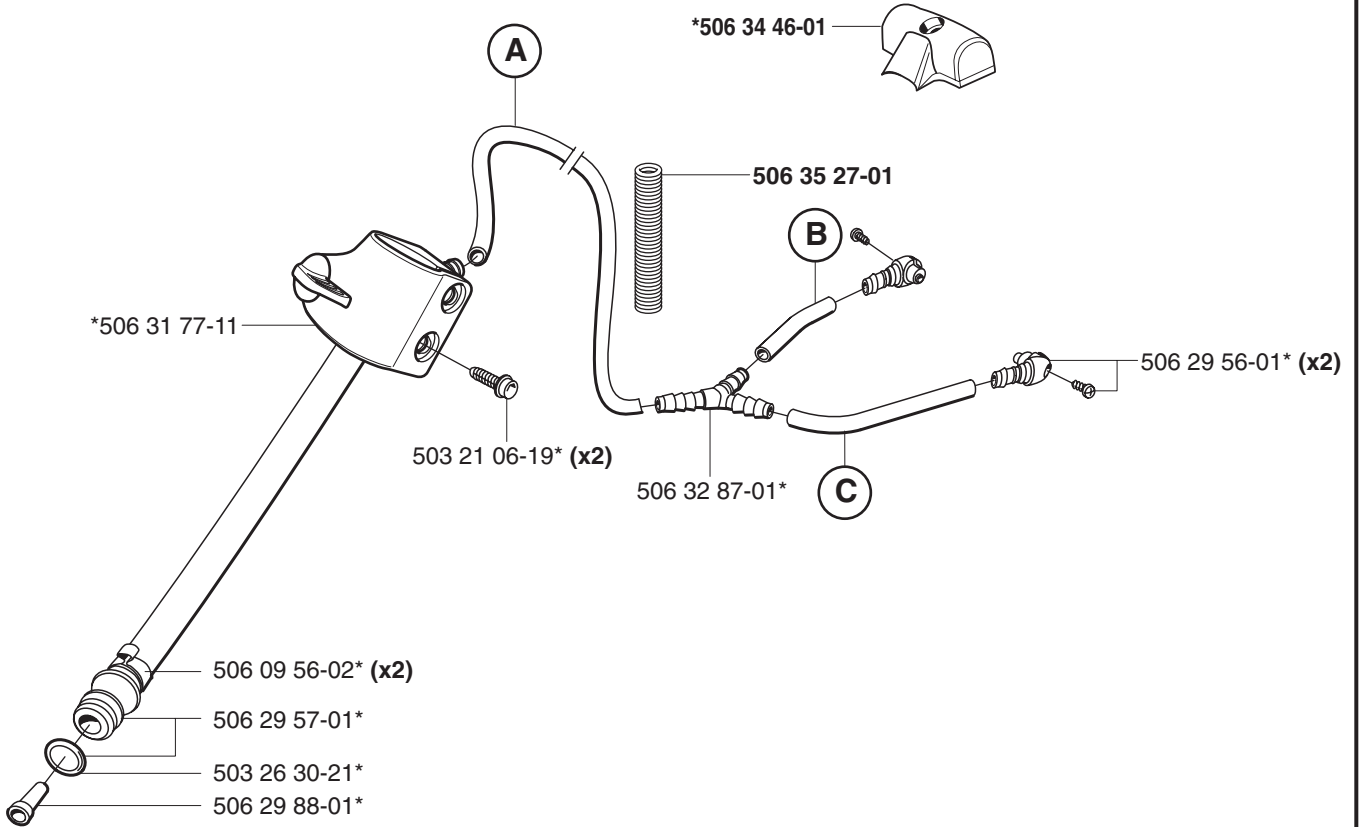

Product		A (mm)	B (mm)	C (mm)
K950A	12"	240	45	240
	14"	240	45	280
	16"	270	45	360

Q Rescue
 *compl 506 34 05-24 (14")

K12 FD FIRE-RESCUE

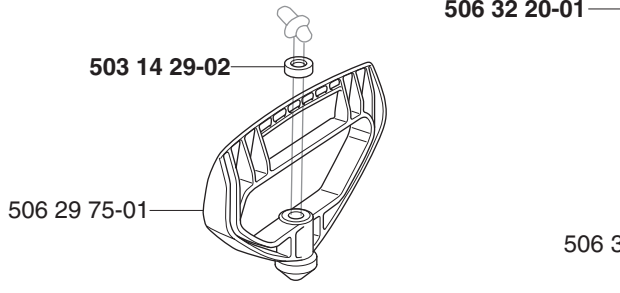

Rescue

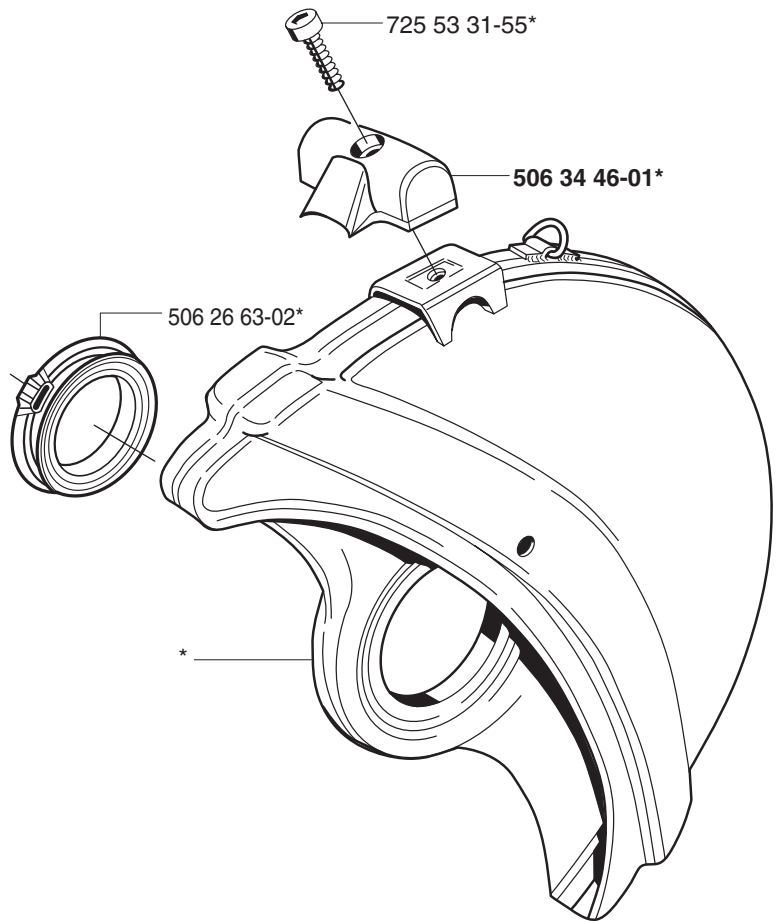

506 30 24-01 PARTNER K950 *Rescue*
 Max 5400 rpm
 Ø 25,4(Ø1") - Ø350(Ø14")

506 32 22-01 **⚠ ATTENTION ⚠**
 This product has been modified for use by trained fire rescue personnel only.

506 30 40-12 (CE)



506 30 40-11 (EPA USA)

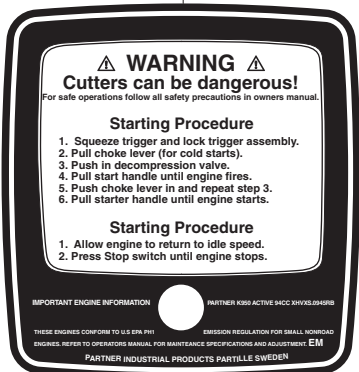

506 30 40-13 (EPA Canada)

